



HEX 3000

HEX 3000

9 high-quality solar panels	Monocrystalline silicon solar panel with carbon fibre coating
Battery storage	Optional
Switch time inverter	<10min
Sun tracing system	Self-learning
Azimuth range	240°
Angle of inclination	0° - 55°
Solar energy charge	<20kWh/per day
Charger	Class 2
Working temperature	-20 °C~60 °C
Total weight	810Kg
Wind resistance	Class 2 – DIN EN12424
Protection level inverter	IP21/IP65
Service and operation tracing system	GPRS/GSM 4G

Panel specifications

Rated peak power	Per panel 200 Wp		
Open circuit voltage	40.8V	Open circuit current	6.1A
Voltage Vmp	34.8V	Current Imp	5.75A

Inverter – storage inverter

Nominal DC Voltage/maximum charger current	48V/80A
Nominal voltage AC	230V
Power	3.000W
PV charger/max. efficiency	98%

Please note, details are subject to change without notice

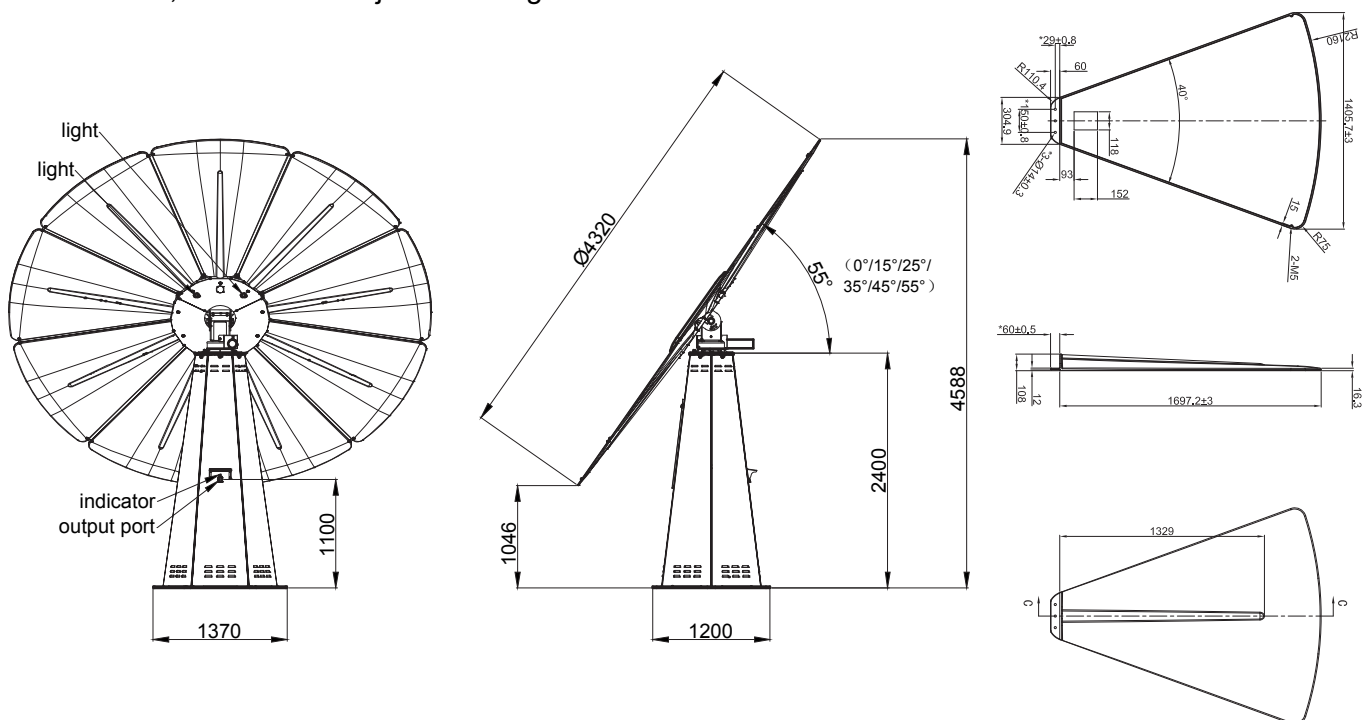

Figure 1. Dimension and diameter HEX3000

Figure 2. Dimension of solar